

ETSI EN 302 574-1 V1.1.1 (2010-08)

Harmonized European Standard (Telecommunications series)

**Satellite Earth Stations and Systems (SES);
Harmonized Standard for satellite earth stations for
MSS operating in the 1 980 MHz to
2 010 MHz (earth-to-space) and 2 170 MHz to
2 200 MHz (space-to-earth) frequency bands;
Part 1: Complementary Ground
Component (CGC) for wideband systems:
Harmonized EN covering the essential requirements
of article 3.2 of the R&TTE Directive**



Reference

DEN/SES-00283-1

Keywords

broadband, IMT 2000, mobile, satellite

ETSI

650 Route des Lucioles
F-06921 Sophia Antipolis Cedex - FRANCE

Tel.: +33 4 92 94 42 00 Fax: +33 4 93 65 47 16

Siret N° 348 623 562 00017 - NAF 742 C
Association à but non lucratif enregistrée à la
Sous-Préfecture de Grasse (06) N° 7803/88

Important notice

Individual copies of the present document can be downloaded from:

<http://www.etsi.org>

The present document may be made available in more than one electronic version or in print. In any case of existing or perceived difference in contents between such versions, the reference version is the Portable Document Format (PDF). In case of dispute, the reference shall be the printing on ETSI printers of the PDF version kept on a specific network drive within ETSI Secretariat.

Users of the present document should be aware that the document may be subject to revision or change of status. Information on the current status of this and other ETSI documents is available at

<http://portal.etsi.org/tb/status/status.asp>

If you find errors in the present document, please send your comment to one of the following services:

http://portal.etsi.org/chaicor/ETSI_support.asp

Copyright Notification

No part may be reproduced except as authorized by written permission.
The copyright and the foregoing restriction extend to reproduction in all media.

© European Telecommunications Standards Institute 2010.
All rights reserved.

DECT™, **PLUGTESTS™**, **UMTS™**, **TIPHON™**, the TIPHON logo and the ETSI logo are Trade Marks of ETSI registered for the benefit of its Members.

3GPP™ is a Trade Mark of ETSI registered for the benefit of its Members and of the 3GPP Organizational Partners.

LTE™ is a Trade Mark of ETSI currently being registered

for the benefit of its Members and of the 3GPP Organizational Partners.

GSM® and the GSM logo are Trade Marks registered and owned by the GSM Association.

Contents

Intellectual Property Rights	6
Foreword.....	6
Introduction	7
1 Scope	8
2 References	9
2.1 Normative references	9
2.2 Informative references.....	9
3 Definitions, symbols and abbreviations	10
3.1 Definitions	10
3.2 Symbols.....	11
3.3 Abbreviations	11
4 Technical requirements specifications	12
4.1 Environmental profile.....	12
4.2 Conformance requirements	12
4.2.1 Introduction.....	12
4.2.2 Spectrum emission mask	12
4.2.2.1 Definition	12
4.2.2.2 Limits	13
4.2.2.3 Conformance.....	14
4.2.3 Adjacent channel leakage power ratio (ACLR).....	14
4.2.3.1 Definition	14
4.2.3.2 Limits	14
4.2.3.3 Conformance.....	15
4.2.4 Transmitter spurious emissions.....	15
4.2.4.1 Definition	15
4.2.4.2 Limits	16
4.2.4.2.1 Spurious emissions	16
4.2.4.2.2 Coexistence with other systems in the same geographical area.....	16
4.2.4.2.3 Protection of UTRA FDD in adjacent frequency band.....	16
4.2.4.2.4 Protection of UTRA -TDD	17
4.2.4.2.5 Protection of UTRA BS.....	17
4.2.4.2.6 Protection of the CGC receiver of own or different CGC	17
4.2.4.3 Conformance.....	18
4.2.5 CGC maximum output power.....	18
4.2.5.1 Definition	18
4.2.5.2 Limit.....	18
4.2.5.3 Conformance.....	18
4.2.6 Transmit inter modulation	18
4.2.6.1 Definition	18
4.2.6.2 Limit.....	18
4.2.6.3 Conformance.....	18
4.2.7 Receiver spurious emissions	19
4.2.7.1 Definition	19
4.2.7.2 Limits	19
4.2.7.3 Conformance.....	19
4.2.8 Blocking characteristics	19
4.2.8.1 Definition	19
4.2.8.2 Limit.....	19
4.2.8.3 Conformance.....	20
4.2.9 Receiver inter-modulation characteristics.....	20
4.2.9.1 Definition	20
4.2.9.2 Limit.....	20
4.2.9.3 Conformance.....	21

4.2.10	Receiver adjacent selectivity.....	21
4.2.10.1	Definition	21
4.2.10.2	Limit.....	21
4.2.10.3	Conformance.....	22
5	Testing for compliance with technical requirements.....	22
5.1	Environmental and other conditions for testing.....	22
5.2	Interpretation of the measurement results	23
5.3	Essential radio test suites.....	25
5.3.1	Spectrum emission mask	25
5.3.1.1	Initial conditions	25
5.3.1.2	Procedures.....	25
5.3.2	Adjacent Channel leakage Power Ratio (ACLR).....	25
5.3.2.1	Initial conditions	25
5.3.2.2	Procedure	26
5.3.3	Transmitter spurious emissions.....	26
5.3.3.1	Initial conditions	26
5.3.3.2	Procedure	26
5.3.4	CGC maximum output power.....	26
5.3.4.1	Initial conditions	26
5.3.4.2	Procedure	26
5.3.5	Transmit intermodulation	27
5.3.5.1	Initial conditions	27
5.3.5.2	Procedures.....	27
5.3.6	Receiver spurious emissions	27
5.3.6.1	Initial conditions	27
5.3.6.2	Procedure	27
5.3.7	Blocking characteristics.....	28
5.3.7.1	Initial conditions	28
5.3.7.2	Procedure	28
5.3.8	Receiver intermodulation characteristics.....	29
5.3.8.1	Initial conditions	29
5.3.8.2	Procedures.....	29
5.3.9	Receiver Adjacent Channel Selectivity (ACS).....	29
5.3.9.1	Initial conditions	29
5.3.9.2	Procedure	29
Annex A (normative):	HS Requirements and conformance Test specifications Table (HS-RTT).....	30
Annex B (normative):	Complementary Ground Component configurations.....	32
B.1	Receiver diversity.....	32
B.2	Duplexers	32
B.3	Splitters.....	32
B.4	Power supply options	33
B.5	Ancillary RF amplifiers.....	33
B.6	CGC using antenna arrays.....	34
B.6.1	Receiver tests.....	34
B.6.2	Transmitter tests	34
B.7	Transmit diversity	35
B.8	CGC with integrated Iuant CGC modem	35
B.9	Combining of CGCs.....	35
Annex C (informative):	Environmental profile specification	36
C.1	Tests environment	36
C.1.1	Measurement of test environments.....	36

C.1.2	Normal test Environment	36
C.1.3	Extreme test environment.....	37
C.1.4	Extreme temperature	37
C.1.5	Vibration.....	37
C.1.6	Power supply	37
C.1.7	Definition of Additive White Gaussian Noise (AWGN) Interferer.....	38
Annex D (informative): Measurement system set-up		39
D.1	Transmitter	39
D.1.1	Maximum output power	39
D.1.2	Out of band emission.....	39
D.1.3	Transmit intermodulation	40
D.2	Receiver.....	40
D.2.1	Adjacent Channel Selectivity (ACS).....	40
D.2.2	Blocking characteristics	41
D.2.3	Intermodulation characteristics	41
D.2.4	Receiver spurious emission	42
Annex E (informative): The EN title in the official languages		43
Annex F (informative): Bibliography.....		44
History		45

Intellectual Property Rights

IPRs essential or potentially essential to the present document may have been declared to ETSI. The information pertaining to these essential IPRs, if any, is publicly available for **ETSI members and non-members**, and can be found in ETSI SR 000 314: "*Intellectual Property Rights (IPRs); Essential, or potentially Essential, IPRs notified to ETSI in respect of ETSI standards*", which is available from the ETSI Secretariat. Latest updates are available on the ETSI Web server (<http://webapp.etsi.org/IPR/home.asp>).

Pursuant to the ETSI IPR Policy, no investigation, including IPR searches, has been carried out by ETSI. No guarantee can be given as to the existence of other IPRs not referenced in ETSI SR 000 314 (or the updates on the ETSI Web server) which are, or may be, or may become, essential to the present document.

Foreword

This Harmonized European Standard (Telecommunications series) has been produced by ETSI Technical Committee Satellite Earth Stations and Systems (SES).

The present document has been produced by ETSI in response to a mandate from the European Commission issued under Council Directive 98/34/EC [i.2] (as amended) laying down a procedure for the provision of information in the field of technical standards and regulations.

The present document is intended to become a Harmonized Standard, the reference of which will be published in the Official Journal of the European Communities referencing the Directive 1999/5/EC [1] of the European Parliament and of the Council of 9 March 1999 on radio equipment and telecommunications terminal equipment and the mutual recognition of their conformity ("the R&TTE Directive").

The requirements relevant to Directive 1999/5/EC [1] are summarised in annex A.

The present document is part 1 of a multi-part deliverable covering the Harmonized Standard for satellite earth stations for MSS operating in the 1 980 MHz to 2 010 MHz (earth-to-space) and 2 170 MHz to 2 200 MHz (space-to-earth) frequency bands, as identified below:

- Part 1: "Complementary Ground Component (CGC) for wideband systems: Harmonized EN covering the essential requirements of article 3.2 of the R&TTE Directive";**
- Part 2: "User Equipment (UE) for wideband systems: Harmonized EN covering essential requirements of article 3.2 of the R&TTE Directive";
- Part 3: "User Equipment (UE) for narrowband systems: Harmonized EN covering essential requirements of article 3.2 of the R&TTE Directive".

National transposition dates	
Date of adoption of this EN:	2 August 2010
Date of latest announcement of this EN (doa):	30 November 2010
Date of latest publication of new National Standard or endorsement of this EN (dop/e):	31 May 2011
Date of withdrawal of any conflicting National Standard (dow):	31 May 2012

Introduction

The present document is part of a set of standards developed by ETSI and is designed to fit in a modular structure to cover all radio and telecommunications terminal equipment within the scope of the R&TTE Directive [1]. The modular structure is shown in EG 201 399 [i.3].

The technical requirements in the present document are adapted from the requirements in EN 301 908-1 [3] and EN 301 908-3 [4]. The adaptations include a variable channel bandwidth and frequency band changes to the MSS band.

1 Scope

The present document applies to Complementary Ground Components (CGC) operating as part of a satellite network. These Complementary Ground Components (CGC) transmit only to the User Equipment or transmit and receive to/from the User Equipment in the frequency bands allocated to the Mobile Satellite Service (MSS) on a primary basis as defined in table 1.

NOTE 1: The CGC may include various types of interfaces, to terrestrial and/or satellite networks, but their specifications are out of the scope of the present document.

The present document applies to Complementary Ground Component (CGC) radio equipment type deployed in Mobile Satellite Services systems which have the following characteristics:

- These CGCs may have both transmit and receive capabilities and are part of a hybrid Satellite/terrestrial network.
- These CGCs operate with an assigned channel signal bandwidth (CBw) of 1 MHz or greater.
- These CGCs may be local coverage, medium coverage or wide coverage ground components.
- These CGCs may be an element in a multi-mode base station. It may consist of a number of modules with associated connections, or may be a self contained single unit.

If the CGC is an element in a multi-mode base station, unless otherwise stated in the present document, its requirements apply only to the CGC element of the terminal operating in the Mobile Satellite Service (MSS) frequency bands given in table 1.

The present document applies to the following terminal equipment types:

- 1) Complementary Ground Components for Wideband Satellite Systems.

This radio equipment type is capable of operating in all or any part of the frequency bands given in table 1.

Table 1: Mobile Satellite Service Complementary Ground Component frequency bands

Operating band	Direction of transmission	CGC frequency bands
I	Transmit	2 170 MHz to 2 200 MHz
	Receive	1 980 MHz to 2 010 MHz

The present document only applies to the radio interface between the CGC and the User Equipment.

The present document is intended to cover the provisions of Directive 1999/5/EC [1] (R&TTE Directive) article 3.2, which states that "..... radio equipment shall be so constructed that it effectively uses the spectrum allocated to terrestrial space radio communications and orbital resources so as to avoid harmful interference".

NOTE 2: In addition to the unwanted emission limits defined in clause 4.2.2 of the present document, additional operational constraints may be required to prevent harmful interference into services operating in the neighbouring bands outside the operational band defined in table 1.

In addition to the present document, other ENs that specify technical requirements in respect of essential requirements under other parts of article 3 of the R&TTE Directive [1] may apply to equipment within the scope of the present document.

NOTE 3: A list of such ENs is included on the web site <http://www.newapproach.org>.

2 References

References are either specific (identified by date of publication and/or edition number or version number) or non-specific. For specific references, only the cited version applies. For non-specific references, the latest version of the reference document (including any amendments) applies.

Referenced documents which are not found to be publicly available in the expected location might be found at <http://docbox.etsi.org/Reference>.

NOTE: While any hyperlinks included in this clause were valid at the time of publication ETSI cannot guarantee their long term validity.

2.1 Normative references

The following referenced documents are necessary for the application of the present document.

- [1] Directive 1999/5/EC of the European Parliament and of the Council of 9 March 1999 on radio equipment and telecommunications terminal equipment and the mutual recognition of their conformity (R&TTE Directive).
- [2] ETSI TS 125 141 (V6.19.0) (2008-04): "Universal Mobile Telecommunications System (UMTS); Base Station (BS) conformance testing (FDD) (3GPP TS 25.141 version 6.19.0 Release 6)".
- [3] ETSI EN 301 908-1 (V3.2.1): "Electromagnetic compatibility and Radio spectrum Matters (ERM); Base Stations (BS), Repeaters and User Equipment (UE) for IMT-2000 Third-Generation cellular networks; Part 1: Harmonized EN for IMT-2000, introduction and common requirements, covering essential requirements of article 3.2 of the R&TTE Directive".
- [4] ETSI EN 301 908-3 (V3.2.1): "Electromagnetic compatibility and Radio spectrum Matters (ERM); Base Stations (BS), Repeaters and User Equipment (UE) for IMT-2000 Third-Generation cellular networks; Part 3: Harmonized EN for IMT-2000, CDMA Direct Spread (UTRA FDD) (BS) covering essential requirements of article 3.2 of the R&TTE Directive".
- [5] ITU-R Recommendation SM.329-10 (02/2003): "Unwanted emissions in the spurious domain".
- [6] ITU-T Recommendation O.153 (10/1992): "Basic parameters for the measurement of error performance at bit rates below the primary rate".
- [7] IEC 60068-2-1 (2007): "Environmental testing - Part 2-1: Tests - Test A: Cold".
- [8] IEC 60068-2-2 (2007): "Environmental testing - Part 2-2: Tests - Test B: Dry heat".
- [9] IEC 60068-2-6 (2007): "Environmental testing - Part 2-6: Tests - Test Fc: Vibration (sinusoidal)".

2.2 Informative references

The following referenced documents are not necessary for the application of the present document but they assist the user with regard to a particular subject area.

- [i.1] ETSI TR 100 028 (all parts): "Electromagnetic compatibility and Radio spectrum Matters (ERM); Uncertainties in the measurement of mobile radio equipment characteristics".
- [i.2] Directive 98/34/EC of the European Parliament and of the Council of 22 June 1998 laying down a procedure for the provision of information in the field of technical standards and regulations.
- [i.3] ETSI EG 201 399: "Electromagnetic compatibility and Radio spectrum Matters (ERM); A guide to the production of candidate Harmonized Standards for application under the R&TTE Directive".
- [i.4] ETSI TR 102 215: "Electromagnetic compatibility and Radio spectrum Matters (ERM); Recommended approach, and possible limits for measurement uncertainty for the measurement of radiated electromagnetic fields above 1 GHz".

- [i.5] ETSI EN 302 574-2: "Satellite Earth Stations and Systems (SES); Harmonized standard for satellite earth stations for MSS operating in the 1 980 MHz to 2 010 MHz (earth-to-space) and 2 170 MHz to 2 200 MHz (space-to-earth) frequency bands; Part 2: User Equipment (UE) for wideband systems: Harmonized EN covering essential requirements of article 3.2 of the R&TTE Directive".
- [i.6] ETSI EN 302 574-3: "Satellite Earth Stations and Systems (SES); Harmonized Standard for satellite earth stations for MSS operating in the 1 980 MHz to 2 010 MHz (earth-to-space) and 2 170 MHz to 2 200 MHz (space-to-earth) frequency bands; Part 3: User Equipment (UE) for narrowband systems: Harmonized EN covering essential requirements of article 3.2 of the R&TTE Directive".
- [i.7] IEC 60721-3-3 (2002): "Classification of environmental conditions - Part 3-3: Classification of groups of environmental parameters and their severities - Stationary use at weatherprotected locations".
- [i.8] IEC 60721-3-4 (1995): "Classification of environmental conditions - Part 3: Classification of groups of environmental parameters and their severities - Section 4: Stationary use at non-weather protected locations".

3 Definitions, symbols and abbreviations

3.1 Definitions

For the purposes of the present document, the terms and definitions given in the R&TTE Directive [1] and the following apply:

ancillary equipment: equipment (apparatus) used in connection with a CGC, which is considered as ancillary equipment (apparatus) if:

- the equipment is intended for use in conjunction with an CGC to provide additional operational and/or control features to the radio equipment, (e.g. to extend control to another position or location);
- the equipment cannot be used on a stand alone basis to provide user functions independently of an CGC; and
- the CGC to which it is connected is capable of providing some intended operation such as transmitting and/or receiving without the ancillary equipment (i.e. it is not a sub-unit of the main equipment essential to the main equipment basic functions).

channel multiplex: set of one or several RF carriers forming one coherent signal

Complementary Ground Component (CGC): ground-based infrastructure at fixed locations used to enhance satellite coverage in zones where communications with one or several space stations cannot be ensured with the required quality

CGC class: wide coverage CGC, medium coverage CGC or local coverage CGC, as declared by the manufacturer

environmental profile: range of environmental conditions under which equipment, within the scope of the present document, is required to comply with the provisions of the present document

local coverage CGC: CGC characterized by requirements derived from picocell scenarios with a CGC to UE minimum coupling loss equal to 45 dB

maximum output power: mean power level per carrier of the CGC measured at the antenna connector in a specified reference condition

mean power: average power (transmitted or received) supplied to the antenna port during an interval of time sufficiently long compared with the lowest frequency encountered in the modulation taken under normal operating conditions

medium coverage CGC: CGC characterized by requirements derived from microcell scenarios with a CGC to UE minimum coupling loss equal to 53 dB

output power: mean power of one carrier of the CGC, delivered to a load with resistance equal to the nominal load impedance of the transmitter

rated output power: rated output power of the CGC is the mean power level per carrier that the manufacturer has declared to be available at the antenna connector

wide coverage CGC: CGC characterized by requirements derived from macrocell scenarios with a CGC to UE minimum coupling loss equal to 70 dB

NOTE: The coupling loss is defined as the space loss that will depend on the propagation channel: Line of Sight, Urban, Suburban, etc.

3.2 Symbols

For the purposes of the present document, the following symbols apply:

α	roll-off factor of the transmitter filter
CBw	Channel multiplex bandwidth (multiplex spacing)
CBw _{assigned}	Assigned channel multiplex bandwidth (multiplex spacing)
CBw _{adjacent}	Adjacent channel multiplex bandwidth (multiplex spacing)
F _{uw}	Frequency of unwanted signal

NOTE: This is specified in bracket in terms of an absolute frequency(s) or a frequency offset from the assigned channel frequency.

Ω	Ohm
----------	-----

3.3 Abbreviations

For the purposes of the present document, the following abbreviations apply:

ACLR	Adjacent Channel Leakage power Ratio
ACS	Adjacent Channel Selectivity
ATT	Attenuator
BER	Bit Error Ratio
BS	Base Station
CDMA	Code Division Multiple Access
CGC	Complementary Ground Component
CW	Continuous Wave (unmodulated signal)
EUT	Equipment Under Test
FDD	Frequency Division Duplexing
F _{uw}	Frequency of unwanted signal
GMSK	Gaussian Minimum Shift Keying
GSM	Global System for Mobile communications
HYB	Hybrid
MS	Mobile Station
MSS	Mobile Satellite Service
QAM	Quadrature Amplitude Modulation
QPSK	Quadrature Phase Shift Keying
R&TTE	Radio and Telecommunications Terminal Equipment
RF	Radio Frequency
RMS	Root Mean Square
RRC	Root-Raised Cosine
Rx	Receiver
TDD	Time Division Duplexing
TTE	Telecommunications Terminal Equipment
Tx	Transmitter
UE	User Equipment
UTRA	Universal Terrestrial Radio Access
WCDMA	Wideband Code Division Multiple Access

4 Technical requirements specifications

4.1 Environmental profile

The technical requirements of the present document apply under the environmental profile for operation of the equipment, which shall be declared by the supplier. The equipment shall comply with all the technical requirements of the present document at all times when operating within the boundary limits of the declared operational environmental profile.

For guidance on how a supplier can declare the environmental profile, see annex C.

4.2 Conformance requirements

The requirements in the present document are based on the assumption that the operating band is shared between systems of the IMT-2000 satellite family or systems having compatible characteristics.

4.2.1 Introduction

To meet the essential requirements under article 3.2 of the R&TTE Directive [1] for IMT-2000 Complementary Ground Component (CGC) seven essential parameters have been identified. Table 2 provides a cross reference between these seven essential parameters and the corresponding nine technical requirements for equipment within the scope of the present document.

Table 2: Cross-references

Essential parameter	Corresponding technical requirements (clause)
Spectrum emissions mask	4.2.2
	4.2.3
Conducted spurious emissions from the transmitter antenna connector	4.2.4
Accuracy of maximum output power	4.2.9
Intermodulation attenuation of the transmitter	4.2.6
Conducted spurious emissions from the receiver antenna connector	4.2.7
Impact of interference on receiver performance	4.2.8
	4.2.9
Receiver adjacent channel selectivity	4.2.10

The supplier shall declare the CGC class and operating band(s) for the CGC. The technical requirements apply for the declared CGC class and operating band(s) as outlined for each requirement. For a CGC supporting more than one operating band, conformance testing for each technical requirement in clause 5 shall be performed for each operating band.

The technical requirements also apply to the CGC configurations described in annex C.

4.2.2 Spectrum emission mask

4.2.2.1 Definition

Out-of-band emissions are unwanted emissions immediately outside the channel bandwidth resulting from the modulation process and non-linearity in the transmitter but excluding spurious emissions. This out-of-band emission limit is specified in terms of a spectrum emission mask and adjacent channel leakage power ratio for the transmitter.

4.2.2.2 Limits

The requirement shall be met by a CGC transmitting on a channel multiplex configured in accordance with the manufacturer's specification. Emissions shall not exceed the maximum level specified in tables 3 to 6 for the appropriate CGC maximum output power, in the frequency range from $\Delta f = 0,5 \text{ CBw}$ to Δf_{max} from the carrier frequency, where:

- Δf is the separation between the carrier frequency and the nominal -3 dB point of the measuring filter closest to the carrier frequency.
- f_{offset} is the separation between the carrier frequency and the centre of the measurement filter.
- $f_{\text{offset}_{\text{max}}}$ is either $(10+\text{CBw}/2)$ MHz or the offset to the MSS Tx band edge, whichever is the greater.
- Δf_{max} is equal to $f_{\text{offset}_{\text{max}}}$ minus half of the bandwidth of the measuring filter.
- In tables 3, 4, 5, 6, f_{offset} and CBw are in MHz.

Table 3: Spectrum emission mask values, CGC for output power $P \geq 43$ dBm

Frequency offset of measurement filter -3 dB point, Δf	Frequency offset of measurement filter centre frequency, f_{offset}	Maximum level	Measurement bandwidth
$\frac{\text{CBw}}{2} \leq \Delta f < \frac{\text{CBw}}{2} + 200 \text{ kHz}$	$\frac{\text{CBw}}{2} + 15 \text{ kHz} \leq f_{\text{offset}} < \frac{\text{CBw}}{2} + 215 \text{ kHz}$	-12,5 dBm	30 kHz
$\frac{\text{CBw}}{2} + 200 \text{ kHz} \leq \Delta f < \frac{\text{CBw}}{2} + 1 \text{ MHz}$	$\frac{\text{CBw}}{2} + 215 \text{ kHz} \leq f_{\text{offset}} < \frac{\text{CBw}}{2} + 1,015 \text{ MHz}$	$-12,5 \text{ dBm} - 15 \times \left[f_{\text{offset}} - \left(\frac{\text{CBw}}{2} + 0,215 \right) \right] \text{ dB}$	30 kHz
$\frac{\text{CBw}}{2} + 1 \text{ MHz} \leq \Delta f < \frac{\text{CBw}}{2} + 1,5 \text{ MHz}$	$\frac{\text{CBw}}{2} + 1,015 \text{ MHz} \leq f_{\text{offset}} < \frac{\text{CBw}}{2} + 1,5 \text{ MHz}$	-24,5 dBm	30 kHz
$\frac{\text{CBw}}{2} + 1,5 \text{ MHz} \leq \Delta f < \Delta f_{\text{max}}$	$\frac{\text{CBw}}{2} + 1,5 \text{ MHz} \leq f_{\text{offset}} < f_{\text{offset}_{\text{max}}}$	-11,5 dBm	1 MHz

Table 4: Spectrum emission mask values, CGC maximum output power $39 \text{ dBm} \leq P < 43 \text{ dBm}$

Frequency offset of measurement filter -3 dB point, Δf	Frequency offset of measurement filter centre frequency, f_{offset}	Maximum level	Measurement bandwidth
$\frac{\text{CBw}}{2} \leq \Delta f < \frac{\text{CBw}}{2} + 200 \text{ kHz}$	$\frac{\text{CBw}}{2} + 15 \text{ kHz} \leq f_{\text{offset}} < \frac{\text{CBw}}{2} + 215 \text{ kHz}$	-12,5 dBm	30 kHz
$\frac{\text{CBw}}{2} + 200 \text{ kHz} \leq \Delta f < \frac{\text{CBw}}{2} + 1 \text{ MHz}$	$\frac{\text{CBw}}{2} + 215 \text{ kHz} \leq f_{\text{offset}} < \frac{\text{CBw}}{2} + 1,015 \text{ MHz}$	$-12,5 \text{ dBm} - 15 \times \left[f_{\text{offset}} - \left(\frac{\text{CBw}}{2} + 0,215 \right) \right] \text{ dB}$	30 kHz
$\frac{\text{CBw}}{2} + 1 \text{ MHz} \leq \Delta f < \frac{\text{CBw}}{2} + 1,5 \text{ MHz}$	$\frac{\text{CBw}}{2} + 1,015 \text{ MHz} \leq f_{\text{offset}} < \frac{\text{CBw}}{2} + 1,5 \text{ MHz}$	-24,5 dBm	30 kHz
$\frac{\text{CBw}}{2} + 1,5 \text{ MHz} \leq \Delta f < \frac{\text{CBw}}{2} + 5 \text{ MHz}$	$\frac{\text{CBw}}{2} + 1,5 \text{ MHz} \leq f_{\text{offset}} < \frac{\text{CBw}}{2} + 5,5 \text{ MHz}$	-11,5 dBm	1 MHz
$\frac{\text{CBw}}{2} + 5 \text{ MHz} \leq \Delta f < \Delta f_{\text{max}}$	$\frac{\text{CBw}}{2} + 5,5 \text{ MHz} \leq f_{\text{offset}} < f_{\text{offset}_{\text{max}}}$	$P - 54,5 \text{ dB}$	1 MHz

Table 5: Spectrum emission mask values, CGC maximum output power $31 \text{ dBm} \leq P < 39 \text{ dBm}$

Frequency offset of measurement filter -3 dB point, Δf	Frequency offset of measurement filter centre frequency, f_{offset}	Maximum level	Measurement bandwidth
$\frac{\text{CBw}}{2} \leq \Delta f < \frac{\text{CBw}}{2} + 200 \text{ kHz}$	$\frac{\text{CBw}}{2} + 15 \text{ kHz} \leq f_{\text{offset}} < \frac{\text{CBw}}{2} + 215 \text{ kHz}$	P - 51,5 dB	30 kHz
$\frac{\text{CBw}}{2} + 200 \text{ kHz} \leq \Delta f < \frac{\text{CBw}}{2} + 1 \text{ MHz}$	$\frac{\text{CBw}}{2} + 215 \text{ kHz} \leq f_{\text{offset}} < \frac{\text{CBw}}{2} + 1,015 \text{ MHz}$	$P - 51,5 \text{ dB} - 15 \times \left[f_{\text{offset}} - \left(\frac{\text{CBw}}{2} + 0,215 \right) \right]$	30 kHz
$\frac{\text{CBw}}{2} + 1 \text{ MHz} \leq \Delta f < \frac{\text{CBw}}{2} + 1,5 \text{ MHz}$	$\frac{\text{CBw}}{2} + 1,015 \text{ MHz} \leq f_{\text{offset}} < \frac{\text{CBw}}{2} + 1,5 \text{ MHz}$	P - 63,5 dB	30 kHz
$\frac{\text{CBw}}{2} + 1,5 \text{ MHz} \leq \Delta f < \frac{\text{CBw}}{2} + 5 \text{ MHz}$	$\frac{\text{CBw}}{2} + 1,5 \text{ MHz} \leq f_{\text{offset}} < \frac{\text{CBw}}{2} + 5,5 \text{ MHz}$	P - 50,5 dB	1 MHz
$\frac{\text{CBw}}{2} + 5 \text{ MHz} \leq \Delta f < \Delta f_{\text{max}}$	$\frac{\text{CBw}}{2} + 5,5 \text{ MHz} \leq f_{\text{offset}} < f_{\text{offset}_{\text{max}}}$	P - 54,5 dB	1 MHz

Table 6: Spectrum emission mask values, CGC maximum output power $P < 31 \text{ dBm}$

Frequency offset of measurement filter -3 dB point, Δf	Frequency offset of measurement filter centre frequency, f_{offset}	Maximum level	Measurement bandwidth
$\frac{\text{CBw}}{2} \leq \Delta f < \frac{\text{CBw}}{2} + 200 \text{ kHz}$	$\frac{\text{CBw}}{2} + 15 \text{ kHz} \leq f_{\text{offset}} < \frac{\text{CBw}}{2} + 215 \text{ kHz}$	-20,5 dBm	30 kHz
$\frac{\text{CBw}}{2} + 200 \text{ kHz} \leq \Delta f < \frac{\text{CBw}}{2} + 1 \text{ MHz}$	$\frac{\text{CBw}}{2} + 215 \text{ kHz} \leq f_{\text{offset}} < \frac{\text{CBw}}{2} + 1,015 \text{ MHz}$	$-20,5 \text{ dBm} - 15 \times \left[f_{\text{offset}} - \left(\frac{\text{CBw}}{2} + 0,215 \right) \right]$	30 kHz
$\frac{\text{CBw}}{2} + 1 \text{ MHz} \leq \Delta f < \frac{\text{CBw}}{2} + 1,5 \text{ MHz}$	$\frac{\text{CBw}}{2} + 1,015 \text{ MHz} \leq f_{\text{offset}} < \frac{\text{CBw}}{2} + 1,5 \text{ MHz}$	-32,5 dBm	30 kHz
$\frac{\text{CBw}}{2} + 1,5 \text{ MHz} \leq \Delta f < \frac{\text{CBw}}{2} + 5 \text{ MHz}$	$\frac{\text{CBw}}{2} + 1,5 \text{ MHz} \leq f_{\text{offset}} < \frac{\text{CBw}}{2} + 5,5 \text{ MHz}$	-19,5 dBm	1 MHz
$\frac{\text{CBw}}{2} + 5 \text{ MHz} \leq \Delta f < \Delta f_{\text{max}}$	$\frac{\text{CBw}}{2} + 5,5 \text{ MHz} \leq f_{\text{offset}} < f_{\text{offset}_{\text{max}}}$	-23,5 dBm	1 MHz

4.2.2.3 Conformance

Conformance tests described in clause 5.3.1 shall be carried out.

4.2.3 Adjacent channel leakage power ratio (ACLR)

4.2.3.1 Definition

Adjacent Channel Leakage power Ratio (ACLR) is the ratio of the filtered mean power centred on the assigned channel frequency to the filtered mean power centred on an adjacent channel frequency not belonging to the same channel multiplex.

4.2.3.2 Limits

The limits to ACLR are measured at frequency offsets which are determined by both the assigned multiplex channel bandwidth $\text{CBw}_{\text{assigned}}$ and the adjacent channel bandwidth $\text{CBw}_{\text{adjacent}}$.

In fact, it is necessary to distinguish two cases:

- Case 1: adjacent channel bandwidth is the same as the assigned channel bandwidth:
 $\text{CBw}_{\text{assigned}} = \text{CBw}_{\text{adjacent}} = \text{CBw}$. In this case, the limits for ACLR shall be as specified in table 7.

- Case 2: adjacent channel bandwidth is different $CBw_{\text{assigned}} \neq CBw_{\text{adjacent}}$. In this case, the limits for ACLR shall be as specified in table 8.

Table 7: CGC ACLR limits for Case 1

CGC channel offset below the first or above the last carrier frequency used	Minimum ACLR requirement
CBw	45 dB
2 × CBw	50 dB
> 2 × CBw	50 dB

Table 8: CGC ACLR limits for Case 2

CGC channel offset below the first or above the last carrier frequency used	Minimum ACLR requirement
1 st adjacent channel centre	45 dB
2 nd adjacent channel centre	50 dB
3 rd adjacent channel centre	50 dB
NOTE: If necessary, the channel offset may be increased by including any operational guard band that is defined.	

4.2.3.3 Conformance

Conformance tests described in clause 5.3.1 shall be carried out.

4.2.4 Transmitter spurious emissions

4.2.4.1 Definition

Spurious emissions are emissions which are caused by unwanted transmitter effects such as harmonics emission, parasitic emission, intermodulation products and frequency conversion products, but exclude out-of-band emissions. This is measured at the CGC RF output port.

The requirements of clause 4.2.4.2 apply at frequencies within the specified frequency ranges, which are more than $(10+CBw/2)$ MHz under the first carrier frequency used or more than $(10+CBw/2)$ MHz above the last carrier frequency used.

The requirements of clause 4.2.4.2 shall apply whatever the type of transmitter considered (single carrier or multi-carrier). It applies for all transmission modes foreseen by the manufacturer's specification.

Unless otherwise stated, all requirements are measured as mean power.

4.2.4.2 Limits

4.2.4.2.1 Spurious emissions

The power of any spurious emission (as defined in clause 4.2.4.1) shall not exceed the limits specified in table 9.

Table 9: CGC mandatory spurious emissions limits

Band	Maximum level	Measurement bandwidth	Note
9 kHz to 150 kHz	-36 dBm	1 kHz	see note 1
150 kHz to 30 MHz	-36 dBm	10 kHz	see note 1
30 MHz to 1 GHz	-36 dBm	100 kHz	see note 1
1 GHz to 2 160 MHz	-30 dBm	1 MHz	see note 1
2 160 MHz to 2 210 MHz	-30 dBm	1 MHz	see note 2
2 210 MHz to 12,75 GHz	-30 dBm	1 MHz	see note 3
NOTE 1: Bandwidth as in ITU-R Recommendation SM.329-10 [5], clause 4.1.			
NOTE 2: Limit based on ITU-R Recommendation SM.329-10 [5], clause 4.3 and annex 7.			
NOTE 3: Bandwidth as in ITU-R Recommendation SM.329-10 [5], clause 4.1. Upper frequency as in ITU-R Recommendation SM.329-10 [5], clause 2.5, table 1.			

4.2.4.2.2 Coexistence with other systems in the same geographical area

These requirements shall be applied for the protection of UE, MS and/or BS/CGC operating in other frequency bands in the same geographical area. The requirements may apply in geographic areas where a system operating in another frequency band than the MSS operating band is deployed. The system operating in the other frequency band may be GSM900, DCS1800, PCS1900, GSM850. The power of any spurious emission shall not exceed the limit specified in table 10.

Table 10: Spurious emissions limits in geographic coverage area of systems operating in other frequency bands for protection of receiver

System type operating in the same geographical area	Band for co-existence requirement	Maximum Level	Measurement Bandwidth
GSM900	921 MHz to 960 MHz	-57 dBm	100 kHz
	876 MHz to 915 MHz	-61 dBm	100 kHz
DCS1800	1 805 MHz to 1 880 MHz	-47 dBm	100 kHz
	1 710 MHz to 1 785 MHz	-61 dBm	100 kHz
PCS1900	1 930 MHz to 1 990 MHz	-47 dBm	100 kHz
	1 850 MHz to 1 910 MHz	-61 dBm	100 kHz
GSM850	869 MHz to 894 MHz	-57 dBm	100 kHz
	824 MHz to 849 MHz	-61 dBm	100 kHz

4.2.4.2.3 Protection of UTRA FDD in adjacent frequency band

The power of any spurious emission shall not exceed the limit specified in table 11.

Table 11: Spurious emissions limits for protection of UTRA FDD receiver in adjacent frequency band

System type operating in the same geographical area	Band for co-existence requirement	Maximum Level	Measurement Bandwidth
UTRA FDD	2 110 MHz to 2 170 MHz	-30 dBm	1 MHz

4.2.4.2.4 Protection of UTRA -TDD

The power of any spurious emission shall not exceed the limit specified in table 12.

Table 12: Spurious emissions limits for protection of UTRA TDD receiver

System type operating in the same geographical area	Band for co-existence requirement	Maximum Level	Measurement Bandwidth
UTRA TDD	1 900 MHz to 1 920 MHz	-52 dBm	1 MHz
	2 010 MHz to 2 025 MHz	-52 dBm	1 MHz
	2 570 MHz to 2 610 MHz	-52 dBm	1 MHz

4.2.4.2.5 Protection of UTRA BS

The terms Wide Area BS, Medium Range BS, Local Area BS are defined in EN 301 908-3 [4].

This requirement may be applied in order to prevent the receivers of other BSs being desensitized by emissions from a CGC transmitter.

The power of any spurious emission may not exceed the limit specified in tables 12a, 12b or 12c depending on the declared Base Station class and operating band.

Table 12a: Spurious emissions limits for protection of a Wide Area BS receiver

Operating band	Band	Maximum level	Measurement bandwidth
I	1 920 MHz to 1 980 MHz	-96 dBm	100 kHz
III	1 710 MHz to 1 785 MHz	-96 dBm	100 kHz
VII	2 500 MHz to 2 570 MHz	-96 dBm	100 kHz
VIII	880 MHz to 915 MHz	-96 dBm	100 kHz

Table 12b: Spurious emissions limits for protection of a Medium Range BS receiver

Operating band	Band	Maximum level	Measurement bandwidth
I	1 920 MHz to 1 980 MHz	-86 dBm	100 kHz
III	1 710 MHz to 1 785 MHz	-86 dBm	100 kHz
VII	2 500 MHz to 2 570 MHz	-86 dBm	100 kHz
VIII	880 MHz to 915 MHz	-86 dBm	100 kHz

Table 12c: Spurious emissions limits for protection of a Local Area BS receiver

Operating band	Band	Maximum level	Measurement bandwidth
I	1 920 MHz to 1 980 MHz	-82 dBm	100 kHz
III	1 710 MHz to 1 785 MHz	-82 dBm	100 kHz
VII	2 500 MHz to 2 570 MHz	-82 dBm	100 kHz
VIII	880 MHz to 915 MHz	-82 dBm	100 kHz

4.2.4.2.6 Protection of the CGC receiver of own or different CGC

This requirement shall be applied in order to prevent the receivers of the CGCs being desensitized by emissions from a CGC transmitter.

The power of any spurious emission (as defined in clause 4.2.4.1) shall not exceed the limits specified in table 13 depending on the declared CGC class.

Table 13: Spurious emissions limits for protection of a CGC receiver

CGC type	Band	Maximum level	Measurement bandwidth
Wide coverage CGC	1 980 MHz to 2 010 MHz	-96 dBm	100 kHz
Medium coverage CGC	1 980 MHz to 2 010 MHz	-86 dBm	100 kHz
Local coverage CGC	1 980 MHz to 2 010 MHz	-82 dBm	100 kHz

4.2.4.3 Conformance

Conformance tests described in clause 5.3.3 shall be carried out.

4.2.5 CGC maximum output power

4.2.5.1 Definition

Maximum output power, P_{max} , of the CGC is the mean power level per carrier measured at the antenna connector in specified reference conditions.

4.2.5.2 Limit

In normal conditions, the CGC maximum output power shall remain within +2,7 dB and -2,7 dB of the manufacturer's rated output power.

In extreme conditions, the CGC maximum output power shall remain within +3,2 dB and -3,2 dB of the manufacturer's rated output power.

4.2.5.3 Conformance

Conformance tests described in clause 5.3.4 shall be carried out.

4.2.6 Transmit inter modulation

4.2.6.1 Definition

The transmit inter modulation performance is a measure of the capability of the transmitter to inhibit the generation of signals in its non-linear elements caused by presence of the wanted signal and an interfering signal reaching the transmitter via the antenna.

The frequency of the interference signal shall be $\pm CBw$, $\pm 2 \times CBw$ and $\pm 3 \times CBw$ offset from the subject signal carrier frequency, but excluding interference frequencies that are outside of the allocated frequency band specified in clause 1.

The requirements are applicable for a channel multiplex.

4.2.6.2 Limit

In the frequency range relevant for this test, the transmit inter-modulation level shall not exceed the Out-of-band emission or the spurious emission requirements of clauses 4.2.2.2, 4.2.3.3 and 4.2.4.2 in the presence of an interference signal with a mean power level 30 dB lower than the mean power of the wanted signal.

4.2.6.3 Conformance

Conformance tests described in clause 5.3.5 shall be carried out.

4.2.7 Receiver spurious emissions

4.2.7.1 Definition

The spurious emission power is the power of the emissions generated or amplified in a receiver that appears at the CGC antenna connector. The requirements apply to all CGC with separate Rx and Tx antenna ports. The test shall be performed when both Tx and Rx are active with the Tx port terminated.

For all CGC with common Rx and Tx antenna port, the transmitter spurious emission as specified in clause 4.2.4 shall apply.

4.2.7.2 Limits

The power of any spurious emission (as defined in clause 4.2.7.1) shall not exceed the limits specified in table 14.

Table 14: Spurious emission requirement

Band	Maximum level	Measurement bandwidth	Note
30 MHz to 1 GHz	-57 dBm	100 kHz	With the exception of frequencies between $(10+CBw/2)$ MHz below the first carrier frequency and $(10+CBw/2)$ MHz above the last carrier frequency used by the CGC transmitter.
1 GHz to 12,75 GHz	-47 dBm	1 MHz	
1 900 MHz to 1 980 MHz and 2 010 MHz to 2 025 MHz	-78 dBm	3,84 MHz	Frequency band for UTRA FDD and TDD BS receivers
1 980 MHz to 2 010 MHz	-78 dBm	CBw	frequency allocation as defined in table 1

4.2.7.3 Conformance

Conformance tests described in clause 5.3.4 shall be carried out.

4.2.8 Blocking characteristics

4.2.8.1 Definition

The blocking characteristics are a measure of the receiver ability to receive a wanted signal at its assigned channel frequency in the presence of an unwanted interferer on frequencies other than those of the adjacent channels

4.2.8.2 Limit

The BER shall not exceed 0,001 for the parameters specified in table 15 depending on the declared CGC class.

Table 15: Blocking characteristics

CGC type	Centre frequency of interfering signal	Interfering signal mean power	Wanted signal mean power	Minimum offset of interfering signal	Type of interfering signal
Wide coverage CGC	1 980 MHz to 2 010 MHz	-40 dBm	-115 dBm	10 MHz	WCDMA
	1 900 MHz to 1980 MHz	-40 dBm	-115 dBm	10 MHz	WCDMA
	1 MHz to 1980 MHz and 2 010 MHz to 12 750 MHz	-15 dBm	-115 dBm		CW carrier
Medium coverage CGC	1 980 MHz to 2 010 MHz	-35 dBm	-105 dBm	10 MHz	WCDMA
	1 900 MHz to 1980 MHz	-35 dBm	-105 dBm	10 MHz	WCDMA
	1 MHz to 1980 MHz and 2 010 MHz to 12 750 MHz	-15 dBm	-115 dBm		CW Carrier
Local coverage CGC	1 980 MHz to 2 010 MHz	-30 dBm	-101 dBm	10 MHz	WCDMA
	1 900 MHz to 1 980 MHz	-30 dBm	-101 dBm	10 MHz	WCDMA
	1 MHz to 1 980 MHz and 2 010 MHz to 12 750 MHz	-15 dBm	-115 dBm		CW carrier

NOTE: The characteristics of the WCDMA interference signal are specified in TS 125 141 [2], annex I.

4.2.8.3 Conformance

Conformance tests described in clause 5.3.7 shall be carried out.

4.2.9 Receiver inter-modulation characteristics

4.2.9.1 Definition

Third and higher order mixing of the two interfering RF signals can produce an interfering signal in the band of the desired channel.

Inter-modulation response rejection is a measure of the capability of the receiver to receive a wanted signal on its assigned channel frequency in the presence of two or more interfering signals which have a specific frequency relationship to the wanted signal.

4.2.9.2 Limit

The BER shall not exceed 0,001 for the parameters specified in tables 16, 17 or 18 depending on the declared CGC class.

Table 16: Interferer signals for Wide Coverage CGC intermodulation performance requirement

Type of signal	Offset	Signal mean power
Wanted signal	-	-115 dBm
CW signal	2 x CBw	-48 dBm
WCDMA signal	2 x CBw	-48 dBm

NOTE: The characteristics of the WCDMA interference signal are specified in TS 125 141 [2], annex I.

Table 17: Interferer signals for Medium Coverage CGC intermodulation performance requirement

Type of signal	Offset	Signal mean power
Wanted signal	-	-105 dBm
CW signal	2 x CBw	-44 dBm
WCDMA signal	2 x CBw	-44 dBm

NOTE: The characteristics of the WCDMA interference signal are specified in TS 125 141 [2], annex I.

Table 18: Interferer signals for Local Coverage CGC intermodulation performance requirement

Type of signal	Offset	Signal mean power
Wanted signal	-	-101 dBm
CW signal	2 x CBw	-38 dBm
WCDMA signal	2 x CBw	-38 dBm
NOTE: The characteristics of the WCDMA interference signal are specified in TS 125 141 [2], annex I.		

4.2.9.3 Conformance

Conformance tests described in clause 5.3.8 shall be carried out.

4.2.10 Receiver adjacent selectivity

4.2.10.1 Definition

Adjacent Channel Selectivity (ACS) is a measure of the receiver's ability to receive a wanted signal at its assigned channel frequency in the presence of an adjacent channel signal at a given frequency offset from the centre frequency of the assigned channel. ACS is the ratio of the receiver filter attenuation on the assigned channel frequency to the receive filter attenuation on the adjacent channel(s).

The interference signal is offset from the wanted signal by the frequency offset F_{uw} which is determined by both the assigned channel bandwidth $CBw_{assigned}$ and the adjacent channel bandwidth $CBw_{adjacent}$.

4.2.10.2 Limit

In case the assigned and the adjacent multiplex are the same bandwidth ($CBw_{assigned} = CBw_{adjacent} = CBw$), the BER shall not exceed 0,001 using the parameters specified in tables 19, 20 or 21 depending on the declared CGC class.

Table 19: Adjacent channel selectivity for Wide Coverage CGC for the same channel characteristic

Parameter	Level	Unit
Reference measurement channel data rate	4,75	kbit/s
Wanted signal mean power	-115	dBm
Interfering signal mean power	-52	dBm
F_{uw} offset (modulated)	$\pm CBw$	MHz

Table 20: Adjacent channel selectivity for Medium Coverage CGC for the same channel characteristic

Parameter	Level	Unit
Reference measurement channel data rate	4,75	Kbit/s
Wanted signal mean power	-105	dBm
Interfering signal mean power	-42	dBm
F_{uw} offset (modulated)	$\pm CBw$	MHz

Table 21: Adjacent channel selectivity for Local Coverage CGC for the same channel characteristic

Parameter	Level	Unit
Reference measurement channel data rate	4,75	Kbit/s
Wanted signal mean power	-101	dBm
Interfering signal mean power	-38	dBm
F_{uw} offset (modulated)	$\pm CBw$	MHz

Else the BER shall not exceed 0,001 using the parameters specified in tables 22, 23 and 24.

Table 22: Adjacent channel selectivity for Wide Coverage CGC for different channel characteristic

Parameter	Level	Unit
Reference measurement channel data rate	4,75	kbit/s
Wanted signal mean power	-115	dBm
Interfering signal mean power	-52	dBm
F_{uw} offset (modulated)	$\pm \left(\frac{CBW_{assigned}}{2} + \frac{CBW_{adjacent}}{2} \right)$	MHz
NOTE: Of necessary a guard band may be introduced.		

Table 23: Adjacent channel selectivity for Medium Coverage CGC for different channel characteristic

Parameter	Level	Unit
Reference measurement channel data rate	4,75	Kbit/s
Wanted signal mean power	-105	dBm
Interfering signal mean power	-42	dBm
F_{uw} offset (modulated)	$\pm \left(\frac{CBW_{assigned}}{2} + \frac{CBW_{adjacent}}{2} \right)$	MHz
NOTE: If necessary a guard band may be introduced.		

Table 24: Adjacent channel selectivity for Local Coverage CGC for different channel characteristic

Parameter	Level	Unit
Reference measurement channel data rate	4,75	Kbit/s
Wanted signal mean power	-101	dBm
Interfering signal mean power	-38	dBm
F_{uw} offset (modulated)	$\pm \left(\frac{CBW_{assigned}}{2} + \frac{CBW_{adjacent}}{2} \right)$	MHz
NOTE: If necessary a guard band may be introduced.		

4.2.10.3 Conformance

Conformance tests described in clause 5.3.9 shall be carried out.

5 Testing for compliance with technical requirements

5.1 Environmental and other conditions for testing

Tests defined in the present document shall be carried out at representative points within the boundary limits of the declared operational environmental profile.

Where technical performance varies subject to environmental conditions, tests shall be carried out under a sufficient variety of environmental conditions (within the boundary limits of the declared operational environmental profile) to give confidence of compliance for the affected technical requirements.

Normally it should be sufficient for all tests to be conducted using normal test conditions except where otherwise stated.

Many tests in the present document are performed with appropriate frequencies in the bottom, middle and top of the operating frequency band of the CGC. These are denoted as RF channels B (bottom), M (middle) and T (top) and are defined as follows:

- RF channel B: the lowest frequency carrier shall be centred on B.
- RF channel M:
 - if the number N of carriers supported is odd, the carrier $(N+1)/2$ shall be centred on M;
 - if the number N of carriers supported is even, the carrier $N/2$ shall be centred on M.
- RF channel T : the highest frequency carrier shall be centred on T.

The measurement system required for each test is described in annex D.

The applicant shall declare the possible values of assigned and adjacent channel bandwidth used by the system. At a minimum, the test cases shall be defined to include all of the declared channel bandwidths. It is assumed that the assigned and adjacent channel bandwidth can respectively fall in the range of 1 MHz to 8 MHz.

5.2 Interpretation of the measurement results

The interpretation of the results recorded in a test report for the measurements described in the present document shall be as follows:

- the measured value related to the corresponding limit will be used to decide whether an equipment meets the requirements of the present document;
- the value of the measurement uncertainty for the measurement of each parameter shall be included in the test report;
- the recorded value of the measurement uncertainty shall be, for each measurement, equal to or lower than the figures in table 25.

For the test methods, according to the present document, the measurement uncertainty figures shall be calculated and shall correspond to an expansion factor (coverage factor) $k = 1,96$ or $k = 2$ (which provide confidence levels of respectively 95 % and 95,45 % in the case where the distributions characterizing the actual measurement uncertainties are normal (Gaussian)). Principles for the calculation of measurement uncertainty are contained in specific TR 100 028 [i.1] or TR 102 215 [i.4].

Table 25 is based on this expansion factor.

In all the relevant clauses in this clause all Bit Error Ratio (BER) measurements shall be carried out according to the general rules for statistical testing defined in ITU-T Recommendation O.153 [6].

Table 25: Maximum uncertainty of the test system

Parameter	Conditions	Uncertainty
Spectrum emissions mask		±1,5 dB
Adjacent Channel Leakage power Ratio (ACLR)		±0,8 dB
Transmitter spurious emissions	For "Spurious emissions": f ≤ 2,3 GHz 2,3 GHz < f ≤ 4 GHz f > 4 GHz For the co-existence requirements: For protection of the CGC receiver:	±1,5 dB ±2,0 dB ±4,0 dB ±2,0 dB ±3,0 dB
CGC maximum output power		±0,7 dB
Transmit inter-modulation	For spectrum emissions mask: For ACLR For "Spurious emissions": f ≤ 2,3 GHz 2,3 GHz < f ≤ 4 GHz f > 4 GHz For co-existence requirements Interference signal	±2,5 dB ±2,2 dB ±2,5 dB ±2,8 dB ±4,5 dB ±2,8 dB ±1,0 dB
Receiver spurious emissions	For CGC receive bands (-78 dBm) Outside the CGC receive bands: f ≤ 2,3 GHz 2,3 GHz < f ≤ 4 GHz f > 4 GHz	±3,0 dB ±2,0 dB ±2,0 dB ±4,0 dB
Blocking characteristics	For offset < 15 MHz: For offset ≥ 15 MHz and f ≤ 2,3 GHz 2,3 GHz < f ≤ 4 GHz f > 4 GHz	±1,4 dB ±1,1 dB ±1,8 dB ±3,2 dB
Receiver inter-modulation characteristics		±1,3 dB
Receiver Adjacent Channel Selectivity (ACS)		±1,1 dB

NOTE 1: For RF tests it should be noted that the uncertainties in table 25 apply to the test system operating into a nominal 50 Ω load and do not include system effects due to mismatch between the EUT and the test system.

NOTE 2: If the test system for a test is known to have a measurement uncertainty greater than that specified in table 25, this equipment can still be used, provided that an adjustment is made follows:

- any additional uncertainty in the test system over and above that specified in table 25 is used to tighten the test requirements - making the test harder to pass (for some tests, e.g. receiver tests, this may require modification of stimulus signals). This procedure will ensure that a test system not compliant with table 25 does not increase the probability of passing an EUT that would otherwise have failed a test if a test system compliant with table 25 had been used.

5.3 Essential radio test suites

5.3.1 Spectrum emission mask

5.3.1.1 Initial conditions

Test environment: Normal; see clause C.1.2.

RF channels to be tested: B, M and T; see clause 5.1.

- 1) Set-up the equipment as shown in annex B. As a general rule, the resolution bandwidth of the measuring equipment should be equal to the measurement bandwidth. However, to improve measurement accuracy, sensitivity, efficiency and avoiding e.g. carrier leakage, the resolution bandwidth may be smaller than the measurement bandwidth. When the resolution bandwidth is smaller than the measurement bandwidth, the result should be integrated over the measurement bandwidth in order to obtain the equivalent noise bandwidth of the measurement bandwidth.
- 2) Measurements with an offset from the carrier centre frequency between $0,5 \times \text{CBw} + 15 \text{ kHz}$ and $(0,5 \times \text{CBw} + 1,5 \text{ MHz})$ shall use a 30 kHz measurement bandwidth.
- 3) Measurements with an offset from the carrier centre frequency between $(0,5 \times \text{CBw} + 1,5 \text{ MHz})$ and $(f_{\text{offset}_{\text{max}}} - 500 \text{ kHz})$ shall use a 1 MHz measurement bandwidth.
- 4) Detection mode: true RMS voltage or true average power.

5.3.1.2 Procedures

- 1) Set the CGC to transmit a signal at the manufacturer's specified maximum output power.
- 2) Step the centre frequency of the measurement filter in contiguous steps and measure the emission within the specified frequency ranges with the specified measurement bandwidth and note that the measured value does not exceed the specified value.

The results obtained shall be compared to the limits in clause 4.2.2.2 in order to prove compliance.

5.3.2 Adjacent Channel leakage Power Ratio (ACLR)

The ACLR related tests shall take into account the two frequency bandwidth cases described in clause 4.2.3.

5.3.2.1 Initial conditions

Test environment: Normal; see clause C.1.2.

RF channels to be tested: B, M and T with multiple carriers if supported; see clause 5.1.

- 1) Connect measurement device to the CGC RF output port as shown in annex D.
- 2) The measurement device characteristics shall be:
 - measurement filter bandwidth: defined in clause 4.2.3.1;
 - detection mode: true RMS voltage or true average power.
- 3) Set the CGC to transmit a signal modulated. The mean power at the RF output port shall be the maximum output power as specified by the manufacturer.
- 4) Set carrier frequency within the frequency band supported by CGC. Minimum carrier spacing shall be CBw and maximum carrier spacing shall be specified by manufacturer.

5.3.2.2 Procedure

Measure conformance with ACLR as defined in clause 4.2.3. In multiple carrier case only offset frequencies below the lowest and above the highest carrier frequency used shall be measured.

The results obtained shall be compared to the limits in clause 4.2.3.3 in order to prove compliance.

5.3.3 Transmitter spurious emissions

5.3.3.1 Initial conditions

Test environment: Normal; see clause C.1.2.

RF channels to be tested: B, M and T with multiple carriers if supported; see clause 5.1.

- 1) Connect the CGC antenna connector to a measurement receiver using an attenuator or a directional coupler if necessary.
- 2) Measurements shall use a measurement bandwidth in accordance to the tables in clause 4.2.4.2.
- 3) Detection mode: true RMS voltage or true average power.
- 4) Configure the CGC with transmitters active at their maximum output power.

5.3.3.2 Procedure

- 1) Set the BC to transmit a signal at the manufacturer's specified maximum output power.
- 2) Measure the emission at the specified frequencies with specified measurement bandwidth and note that the measured value does not exceed the specified value.

The results obtained shall be compared to the limits in clause 4.2.4.2 in order to prove compliance.

5.3.4 CGC maximum output power

5.3.4.1 Initial conditions

Test environment: Normal; see clause C.1.2.

RF channels to be tested: B, M and T; see clause 5.1.

In addition, on one channel only, the test shall be performed under extreme power supply as defined in clause C.1.6.

- 1) Connect the power measuring equipment to the CGC RF output port.

5.3.4.2 Procedure

- 1) Set the CGC to transmit a signal modulated with a combination of control and dedicated physical channels specified.
- 2) Measure the mean power at the RF output port.

The results obtained shall be compared to the limits in clause 4.2.5.2 in order to prove compliance.

5.3.5 Transmit intermodulation

5.3.5.1 Initial conditions

Test environment: Normal; see clause C.1.2.

RF channels to be tested: B, M and T; see clause 5.1.

- a) Test set-up in accordance to annex D.

5.3.5.2 Procedures

- 1) Generate the wanted signal at specified maximum CGC output power.
- 2) Generate the interference signal with frequency offset of CBw relative to the wanted signal, but excluding interference frequencies that are outside of the allocated frequency band for MSS downlink specified in the scope of the present document.
- 3) Adjust ATT1 so the level of the modulated interference signal at CGC is 30 dB below the wanted signal.
- 4) Perform the out-of-band emission tests as specified in clauses 5.3.1 and 5.3.2 for all third and fifth order intermodulation products which appear in the frequency ranges defined in clauses 5.3.1 and 5.3.2. The width of the intermodulation products shall be taken into account.
- 5) Perform the spurious emission test as specified in clause 5.3.3 for all third and fifth order intermodulation products which appear in the frequency ranges defined in clause 5.3.3. The width of the intermodulation products shall be taken into account.
- 6) Verify that the emission level does not exceed the required level with the exception of interference signal frequencies.
- 7) Repeat the test for interference frequency off set of $-CBw$, but excluding interference frequencies that are outside of the allocated frequency band for MSS downlink specified in the scope of the present document.
- 8) Repeat the test for interference frequency off set of $\pm 2 \times CBw$ and $\pm 3 \times CBw$, but excluding interference frequencies that are outside of the allocated frequency band for MSS downlink specified in the scope of the present document.

The results obtained shall be compared to the limits in clause 4.2.6.2 in order to prove compliance.

5.3.6 Receiver spurious emissions

5.3.6.1 Initial conditions

Test environment: Normal; see clause C.1.2.

RF channels to be tested: M, with multi-carrier if supported; see clause 5.1.

- 1) Connect a measurement receiver to the CGC antenna connector as shown in annex D.
- 2) Enable the CGC receiver.
- 3) Start CGC transmission at manufacturer's specified maximum output power.

5.3.6.2 Procedure

- 1) Terminate the CGC Tx antenna connector as shown in annex D.
- 2) Set measurement equipment parameters as specified in table 26.
- 3) Measure the spurious emissions over each frequency range described in clause 4.2.7.2.
- 4) Repeat the test using diversity antenna connector if available.

Table 26: Measurement equipment parameters

Measurement bandwidth	as in table 13
Sweep frequency range	30 MHz to 12,75 GHz
Detection	true RMS voltage or true average power

The results obtained shall be compared to the limits in clause 4.2.7.2 in order to prove compliance.

5.3.7 Blocking characteristics

5.3.7.1 Initial conditions

Test environment: Normal; see clause C.1.2.

RF channels to be tested: M; see clause 5.1.

The CGC shall be configured to operate as close to the centre of the operating band as possible.

- 1) Connect signal generator at the assigned channel frequency of the wanted signal and a signal generator to the antenna connector of one Rx port.
- 2) Terminate any other Rx port not under test.
- 3) Transmit a signal from the signal generator to the CGC. The characteristics of the signal shall be set according to the Uplink (from UE to CGC) reference measurement channel. The level of the signal measured at the CGC antenna connector shall be set to the level specified in clause 4.2.8.2.

5.3.7.2 Procedure

- 1) Set the signal generator to produce an interfering signal at a frequency offset F_{uw} from the assigned channel frequency of the wanted signal which is given by:

$$F_{uw} = \pm(n \times 1 \text{ MHz});$$

where n shall be increased in integer steps from $n = 10$ up to such a value that the centre frequency of the interfering signal covers the range from 1 MHz to 12,75 GHz. The interfering signal level measured at the antenna connector shall be set in dependency of its centre frequency, as specified in table 15. The type of the interfering signal is either equivalent to a continuous WCDMA signal with one code of chip frequency 3,84 Mchip/s, filtered by an RRC transmit pulse-shaping filter with roll-off $\alpha = 0,22$, a CW signal or a GMSK, QPSK or 16 QAM modulated signal.

- 2) Measure the BER of the wanted signal at the CGC receiver.
- 3) Interchange the connections of the CGC Rx ports and repeat the measurements according to steps (1) to (2).

NOTE: TS 125 141 [2], annex C describes the procedure for BER tests taking into account the statistical consequence of frequent repetition of BER measurements within the blocking test. The consequence is: a DUT exactly on the limit may fail due to the statistical nature 2,55 times (mean value) in 12 750 BER measurements using the predefined wrong decision probability of 0,02 %. If the fail cases are ≤ 12 , it is allowed to repeat the fail cases one time before the final verdict.

The results obtained shall be compared to the limits in clause 4.2.8.2 in order to prove compliance.

5.3.8 Receiver intermodulation characteristics

5.3.8.1 Initial conditions

Test environment: Normal; see clause C.1.2.

RF channels to be tested: B, M and T; see clause 5.1.

- 1) Set-up the equipment as shown in annex D.

5.3.8.2 Procedures

- 1) Generate the wanted signal (reference signal) and adjust ATT1 to set the signal level to the CGC under test to the level specified in table 16.
- 2) Adjust the signal generators to type of interfering signal and frequency offset from the frequency of the wanted signal, as specified in tables 16 and 17. The type of the interfering signal is a CW signal.
- 3) Adjust the ATT2 and ATT3 to obtain the specified level of interference signal at the CGC input.
- 4) Measure the BER.
- 5) Repeat the test for interference signal frequency offset of $-2 \times \text{CBw}$ and $-4 \times \text{CBw}$.
- 6) Repeat the whole test for the port which was terminated.

The results obtained shall be compared to the limits in clause 4.2.9.2 in order to prove compliance.

5.3.9 Receiver Adjacent Channel Selectivity (ACS)

5.3.9.1 Initial conditions

Test environment: Normal; see clause C.1.2.

RF channels to be tested: B, M and T; see clause 5.1.

- 1) Set-up the equipment as shown in annex D.

5.3.9.2 Procedure

- 1) Generate the wanted signal and adjust the ATT1 to set the input level to the CGC under test to the level specified in table 19.
- 2) Set-up the interference signal at the adjacent channel frequency and adjust the ATT2 to obtain the specified level of interference signal at the CGC input defined in table 19. Note that the interference signal shall have an ACLR of at least 63 dB in order to eliminate the impact of interference signal adjacent channel leakage power on the ACS measurement.
- 3) Measure the BER.
- 4) Repeat the test for the port, which was terminated.

The results obtained shall be compared to the limits in clause 4.2.10.2 in order to prove compliance.

Annex A (normative): HS Requirements and conformance Test specifications Table (HS-RTT)

The HS Requirements and conformance Test specifications Table (HS-RTT) in table A.1 serves a number of purposes, as follows:

- it provides a statement of all the requirements in words and by cross reference to (a) specific clause(s) in the present document or to (a) specific clause(s) in (a) specific referenced document(s);
- it provides a statement of all the test procedures corresponding to those requirements by cross reference to (a) specific clause(s) in the present document or to (a) specific clause(s) in (a) specific referenced document(s);
- it qualifies each requirement to be either:
 - Unconditional: meaning that the requirement applies in all circumstances; or
 - Conditional: meaning that the requirement is dependant on the manufacturer having chosen to support optional functionality defined within the schedule.
- in the case of Conditional requirements, it associates the requirement with the particular optional service or functionality;
- it qualifies each test procedure to be either:
 - Essential: meaning that it is included with the Essential Radio Test Suite and therefore the requirement shall be demonstrated to be met in accordance with the referenced procedures;
 - Other: meaning that the test procedure is illustrative but other means of demonstrating compliance with the requirement are permitted.

Table A.1: HS Requirements and conformance Test specifications Table (HS-RTT)

Harmonized Standard EN 302-574-1						
The following requirements and test specifications are relevant to the presumption of conformity under the article 3.2 of the R&TTE Directive						
Requirement			Requirement Conditionality		Test Specification	
No	Description	Reference: Clause No	U/C	Condition	E/O	Reference: Clause No
1	Spectrum emission mask	4.2.2	U		E	5.3.1
2	Adjacent Channel Leakage ratio (ACLR)	4.2.3	U		E	5.3.2
3	Transmitter spurious emission	4.2.4	U		E	5.3.3
4	CGC Maximum output power	4.2.5	U		E	5.3.4
5	Transmit intermodulation	4.2.6	U		E	5.3.5
6	Receiver spurious emission	4.2.7	U		E	5.3.6
7	Blocking characteristics	4.2.8	U		E	5.3.7
8	Receiver intermodulation characteristics	4.2.9	U		E	5.3.8
9	Receiver Adjacent Channel Selectivity (ACS)	4.2.10	U		E	5.3.9

Key to columns:**Requirement:**

No A unique identifier for one row of the table which may be used to identify a requirement or its test specification.

Description A textual reference to the requirement.

Clause Number Identification of clause(s) defining the requirement in the present document unless another document is referenced explicitly.

Requirement Conditionality:

U/C Indicates whether the requirement is to be *unconditionally* applicable (U) or is *conditional* upon the manufacturers claimed functionality of the equipment (C).

Condition Explains the conditions when the requirement shall or shall not be applicable for a technical requirement which is classified "conditional".

Test Specification:

E/O Indicates whether the test specification forms part of the Essential Radio Test Suite (E) or whether it is one of the Other Test Suite (O).

NOTE: All tests whether "E" or "O" are relevant to the requirements. Rows designated "E" collectively make up the Essential Radio Test Suite; those designated "O" make up the Other Test Suite; for those designated "X" there is no test specified corresponding to the requirement. The completion of all tests classified "E" as specified with satisfactory outcomes is a necessary condition for a presumption of conformity. Compliance with requirements associated with tests classified "O" or "X" is a necessary condition for presumption of conformity, although conformance with the requirement may be claimed by an equivalent test or by manufacturer's assertion supported by appropriate entries in the technical construction file.

Clause Number Identification of clause(s) defining the test specification in the present document unless another document is referenced explicitly. Where no test is specified (that is, where the previous field is "X") this field remains blank.

Annex B (normative): Complementary Ground Component configurations

B.1 Receiver diversity

For the tests in clause 5, the specified test signals shall be applied to one receiver antenna connector, with the remaining receivers are disabled or their antenna connectors being terminated with.

B.2 Duplexers

The requirements of the present document shall be met with a duplexer fitted, if a duplexer is supplied as part of the CGC. If the duplexer is supplied as an option by the manufacturer, sufficient tests should be repeated with and without the duplexer fitted to verify that the CGC meets the requirements of the present document in both cases.

The following tests should be performed with the duplexer fitted, and without it fitted if this is an option:

- 1) Clause 5.3.4, CGC maximum output power, for the highest static power step only, if this is measured at the antenna connector.
- 2) Clause 5.3.3, output RF spectrum emissions; outside the CGC transmit band.
- 3) Clause 5.3.5, transmit intermodulation; for the testing of conformance, the carrier frequencies should be selected to minimize intermodulation products from the transmitters falling in receive channels. The remaining tests may be performed with or without the duplexer fitted.

NOTE 1: When performing receiver tests with a duplexer fitted, it is important to ensure that the output from the transmitters does not affect the test apparatus. This can be achieved using a combination of attenuators, isolators and filters.

NOTE 2: When duplexers are used, intermodulation products will be generated, not only in the duplexer but also in the antenna system. The intermodulation products generated in the antenna system are not controlled by the specifications, and may degrade during operation (e.g. due to moisture ingress). Therefore, to ensure continued satisfactory operation of a CGC, an operator will normally select channels to minimize intermodulation products falling on receive channels. For testing of complete conformance, an operator may specify the channels to be used.

B.3 Splitters

The requirements of the present document shall be met with a splitter fitted, if a splitter is supplied as part of the CGC. If the splitter is supplied as an option by the manufacturer, sufficient tests should be repeated with and without the splitter fitted to verify that the CGC meets the requirements of the present document in both cases.

When a splitter is supplied as part of the CGC, the test signal shall be measured at each output of the splitter.

The following tests should be performed with the splitter fitted, and without it fitted if this is an option:

- 1) Clause 5.3.4, CGC maximum output power, for the highest static power step only, if this is measured at the antenna connector.
- 2) Clause 5.3.1, Spectrum emission mask.
- 3) Clause 5.3.3, output RF spectrum emissions; outside the CGC transmit band.
- 4) Clause 5.3.5, transmit intermodulation; for the testing of conformance, the carrier frequencies should be selected to minimize intermodulation products from the transmitters falling in receive channels. The remaining tests may be performed with or without the duplexer fitted.

NOTE: When performing receiver tests with a duplexer fitted, it is important to ensure that the output from the transmitters does not affect the test apparatus. This can be achieved using a combination of attenuators, isolators and filters.

B.4 Power supply options

If the CGC is supplied with a number of different power supply configurations, it may not be necessary to test RF parameters for each of the power supply options, provided that it can be demonstrated that the range of conditions over which the equipment is tested is at least as great as the range of conditions due to any of the power supply configurations.

This applies particularly if a CGC contains a DC rail which can be supplied either externally or from an internal mains power supply. In this case, the conditions of extreme power supply for the mains power supply options can be tested by testing only the external DC supply option. The range of DC input voltages for the test should be sufficient to verify the performance with any of the power supplies, over its range of operating conditions within the CGC, including variation of mains input voltage, temperature and output current.

B.5 Ancillary RF amplifiers

This clause applies to a CGC which incorporates an ancillary amplifier.

The ancillary amplifier is incorporated into the CGC by a connecting network (including any cable(s), attenuator(s), etc.) with applicable loss to make sure the appropriate operating conditions of complete CGC including the ancillary amplifier. The applicable connecting network loss range is declared by the manufacturer. Other characteristics and the temperature dependence of the attenuation of the connecting network are neglected. The actual attenuation value of the connecting network is chosen for each test as one of the applicable extreme values. The lowest value is used unless otherwise stated.

Sufficient tests should be repeated with the ancillary amplifier fitted and, if it is optional, without the ancillary RF amplifier to verify that the CGC meets the requirements of the present document in both cases.

When testing, the following tests should be repeated with the optional ancillary amplifier fitted according to table B.1, where x denotes that the test is applicable.

Table B.1: Table of tests applicable to Ancillary RF Amplifiers

	Clause	Tx amplifier only	Rx amplifier only	Tx/Rx amplifiers combined (see note)
Receiver Tests	5.3.7			
	5.3.8			
	5.3.6			
Transmitter Tests	5.3.4	X		X
	5.3.3	X		X
	5.3.5	X		X
NOTE: Combining can be by duplex filters or any other network. The amplifiers can either be in Rx or Tx branch or in both. Either one of these amplifiers could be a passive network.				

In test according to clause 5.3.4, the highest applicable attenuation value is applied.

B.6 CGC using antenna arrays

This clause applies to CGC that incorporate antenna arrays.

A CGC may be configured with a multiple antenna port connection for some or all of its transceivers or with an antenna array related to one sector (not one array per transceiver). This clause applies to a CGC which meets at least one of the following conditions:

- the transmitter output signals from one or more transceiver appear at more than one antenna port per sector in the case of sectorized CGC; or
- there is more than one receiver antenna port for a transceiver or per cell and an input signal is required at more than one port for the correct operation of the receiver thus the outputs from the transmitters as well as the inputs to the receivers are directly connected to several antennas (known as "air combining"); or
- transmitters and receivers are connected via duplexers to more than one antenna.

NOTE: Diversity reception does not meet this requirement.

In case of diversity, main and diversity antenna are not considered as an antenna array.

If a CGC is used, in normal operation, in conjunction with an antenna system which contains filters or active elements which are necessary to meet the requirements, the conformance tests may be performed on a system comprising the CGC together with these elements, supplied separately for the purposes of testing. In this case, it must be demonstrated that the performance of the configuration under test is representative of the system in normal operation, and the conformance assessment is only applicable when the CGC is used with the antenna system.

For conformance testing of such a CGC, the following procedure may be used.

B.6.1 Receiver tests

Power of the signals applied is equal to the power of the test signal(s) specified in the test.

An example of a suitable test configuration is shown in figure B.1.

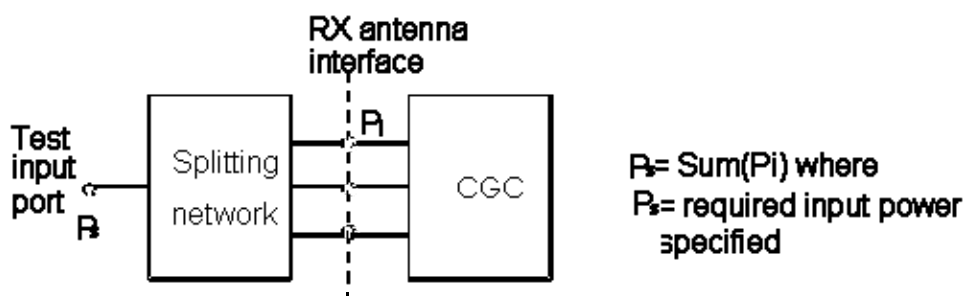

Figure B.1: Receiver test set-up

For spurious emissions from the receiver antenna connector, the test may be performed separately for each receiver antenna connector.

B.6.2 Transmitter tests

For each test, the test signals applied to the transmitter antenna connectors (P_i) shall be such that the sum of the powers of the signals applied equals the power of the test signal(s) (P_T) specified in the test. This may be assessed by separately measuring the signals emitted by each antenna connector and summing the results, or by combining the signals and performing a single measurement. The characteristics (e.g. amplitude and phase) of the combining network should be such that the power of the combined signal is maximized.

An example of a suitable test configuration is shown in figure B.2.

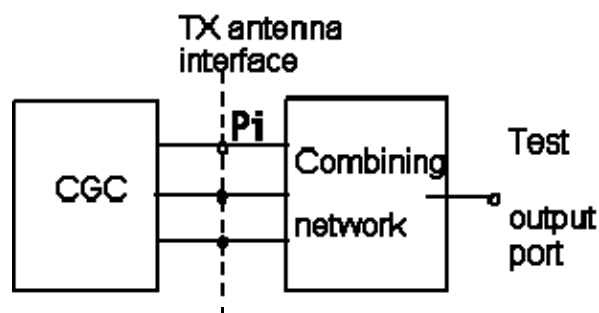

Figure B.2: Transmitter test set-up

B.7 Transmit diversity

Unless otherwise stated, for the tests in clause 5 of the present document, the signal shall be measured at both main and diversity transmitters antenna connectors, with the remaining antenna connector being terminated.

B.8 CGC with integrated Iuant CGC modem

Unless otherwise stated, for the tests in the present document, the integrated Iuant CGC modem shall be switched off. Spurious emissions according to clause 5.3.3 shall be measured only for frequencies above $4 \times \text{CBw}$ with the integrated Iuant CGC modem switched on.

B.9 Combining of CGCs

If the CGC is intended for combination with additional apparatus connected to a CGC port and this combination is supplied as a system, the combination of CGC together with the additional apparatus must also fulfil the CGC requirements. E.g. if the CGC is intended for combination such that multiple CGCs amplify the same signals into the same ports the combination must also fulfil the CGC requirements.

An example of such a configuration is shown in figure B.3.

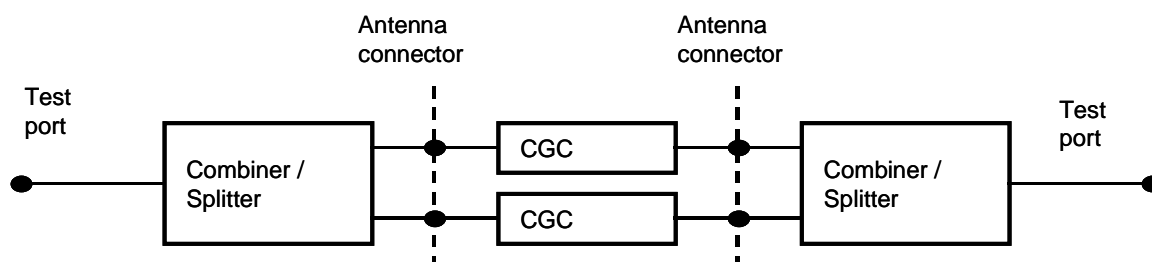

Figure B.3: Example of CGC configuration

Annex C (informative): Environmental profile specification

The following environmental conditions may be declared by the supplier :

- barometric pressure: minimum and maximum;
- temperature: minimum and maximum;
- relative humidity: minimum and maximum;
- power supply: lower and upper voltage limit.

When operating outside the boundary limits of the declared operational environmental profile the equipment should not make ineffective use of the radio frequency spectrum so as to cause harmful interference.

C.1 Tests environment

C.1.1 Measurement of test environments

The measurement accuracy of the CGC normal test environments should be:

Pressure:	±5 kPa.
Temperature:	±2 degrees.
Relative Humidity:	±5 %.
DC Voltage:	±1,0 %.
AC Voltage:	±1,5 %.
Vibration:	10 %.
Vibration frequency:	0,1 Hz.

The above values should apply unless the test environment is otherwise controlled and the specification for the control of the test environment specifies the uncertainty for the parameter.

For each test in the present document, the environmental conditions under which the CGC is to be tested are defined.

C.1.2 Normal test Environment

When a normal test environment is specified for a test, the test should be performed within the minimum and maximum limits of the conditions stated in table C.1.

Table C.1: Limits of conditions for Normal Test Environment

Condition	Minimum	Maximum
Barometric pressure	86 kPa	106 kPa
Temperature	15 °C	30 °C
Relative Humidity	20 %	85 %
Power supply	Nominal, as declared by the manufacturer	
Vibration	Negligible	

The ranges of barometric pressure, temperature and humidity represent the maximum variation expected in the uncontrolled environment of a test laboratory. If it is not possible to maintain these parameters within the specified limits, the actual values should be recorded in the test report.

NOTE: This may, for instance, be the case for measurements of radiated emissions performed on an open field test site.

C.1.3 Extreme test environment

The manufacturer should declare one of the following:

- 1) the equipment class for the equipment under test, as defined in the IEC 60721-3-3 [i.7];
- 2) the equipment class for the equipment under test, as defined in the IEC 60721-3-4 [i.8];
- 3) the equipment that does not comply to the mentioned classes, the relevant classes from IEC 60721-3-3 [i.7] and IEC 60721-3-4 [i.8] documentation for Temperature, Humidity and Vibration should be declared.

NOTE: Reduced functionality for conditions that fall outside of the standard operational conditions is not tested in the present document. These may be stated and tested separately.

C.1.4 Extreme temperature

When an extreme temperature test environment is specified for a test, the test should be performed at the standard minimum and maximum operating temperatures defined by the manufacturers' declaration for the equipment under test.

Minimum temperature:

The test should be performed with the environment test equipment and methods including the required environmental phenomena into the equipment, conforming to the test procedure of IEC 60068-2-1 [7].

Maximum temperature:

The test should be performed with the environmental test equipment and methods including the required environmental phenomena into the equipment, conforming to the test procedure of IEC 60068-2-2 [8].

NOTE: It is recommended that the equipment is made fully operational prior to the equipment being taken to its lower operating temperature.

C.1.5 Vibration

When vibration conditions are specified for a test, the test should be performed while the equipment is subjected to a vibration sequence as defined by the manufacturer's declaration for the equipment under test. This should use the environmental test equipment and methods of inducing the required environmental phenomena in to the equipment, conforming to the test procedure of IEC 60068-2-6 [9]. Other environmental conditions should be within the ranges specified in clause C.1.2.

NOTE: The higher levels of vibration may induce undue physical stress in to equipment after a prolonged series of tests. The testing body should only vibrate the equipment during the RF measurement process.

C.1.6 Power supply

When extreme power supply conditions are specified for a test, the test should be performed at the standard upper and lower limits of operating voltage defined by manufacturer's declaration for the equipment under test.

Upper voltage limit:

The equipment should be supplied with a voltage equal to the upper limit declared by the manufacturer (as measured at the input terminals to the equipment). The tests should be carried out at the steady state minimum and maximum temperature limits declared by the manufacturer for the equipment, to the methods described in IEC 60068-2-1 [7] Test Ab/Ad and IEC 60068-2-2 [8] Test Bb/Bd: Dry Heat.

Lower voltage limit:

The equipment should be supplied with a voltage equal to the lower limit declared by the manufacturer (as measured at the input terminals to the equipment). The tests should be carried out at the steady state minimum and maximum temperature limits declared by the manufacturer for the equipment, to the methods described in IEC 60068-2-1 [7] Test Ab/Ad and IEC 60068-2-2 [8] Test Bb/Bd: Dry Heat.

C.1.7 Definition of Additive White Gaussian Noise (AWGN) Interferer

The minimum bandwidth of the AWGN interferer should be 1,5 times symbol rate of the radio access mode. (e.g. 5,76 MHz for a chip rate of 3,84 Mcps). The flatness across this minimum bandwidth should be less than $\pm 0,5$ dB and the peak to average ratio at a probability of 0,001 % should exceed 10 dB.

Annex D (informative): Measurement system set-up

Example of measurement system set-ups are attached below as an informative annex.

The block diagram of the measurement set-up for the maximum output power testing is shown in figure D.1.

The block diagram of the measurement set-up for the out of band emission testing is shown in figure D.2.

The block diagram of the measurement set-up for the transmit intermodulation testing is shown in figure D.3.

D.1 Transmitter

D.1.1 Maximum output power

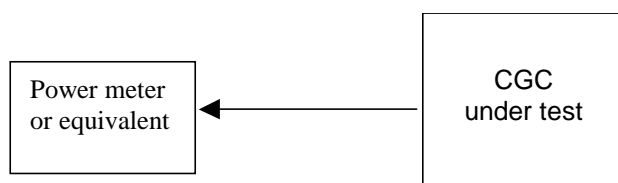

Figure D.1: Measuring system Set-up for maximum output power, total power dynamic range

D.1.2 Out of band emission

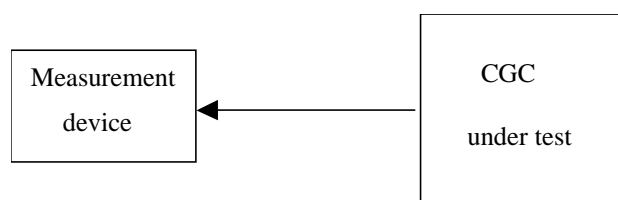

Figure D.2: Measuring system Set-up for Out of band emission measurements

The measurement device is used to measure out of band emission.

D.1.3 Transmit intermodulation

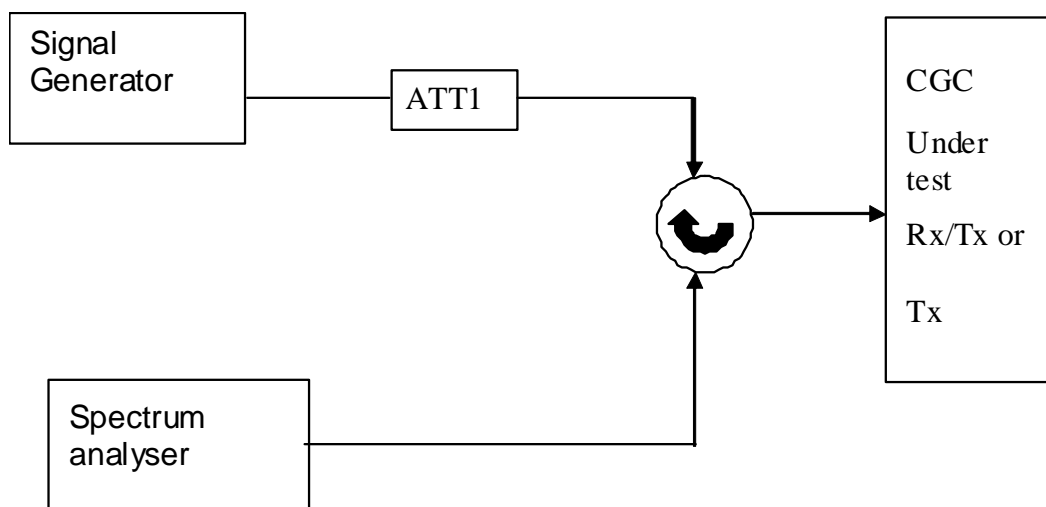

Figure D.3: Measuring system Set-up for CGC Transmit Intermodulation Tests

D.2 Receiver

D.2.1 Adjacent Channel Selectivity (ACS)

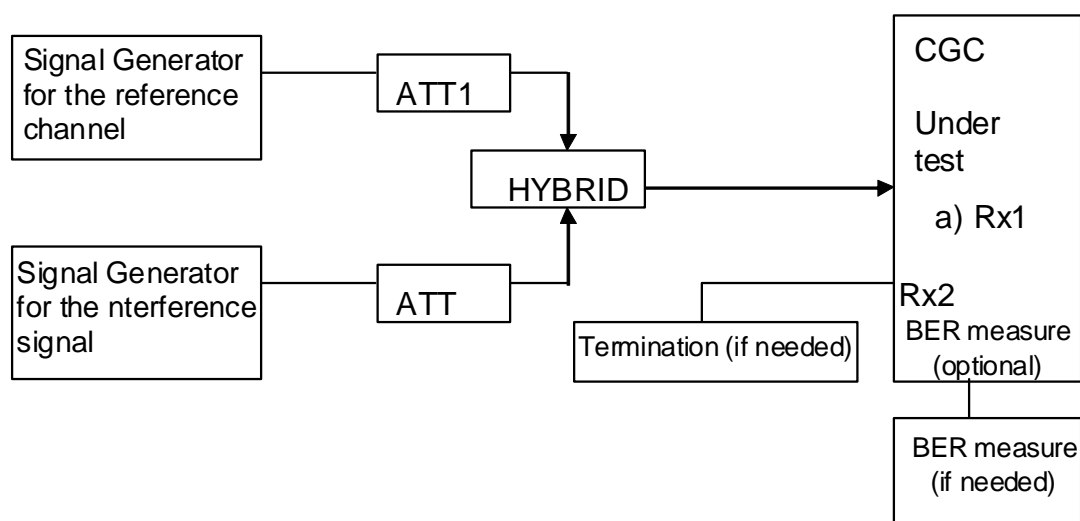

Figure D.4: Measuring system Set-up for Adjacent channel selectivity

D.2.2 Blocking characteristics

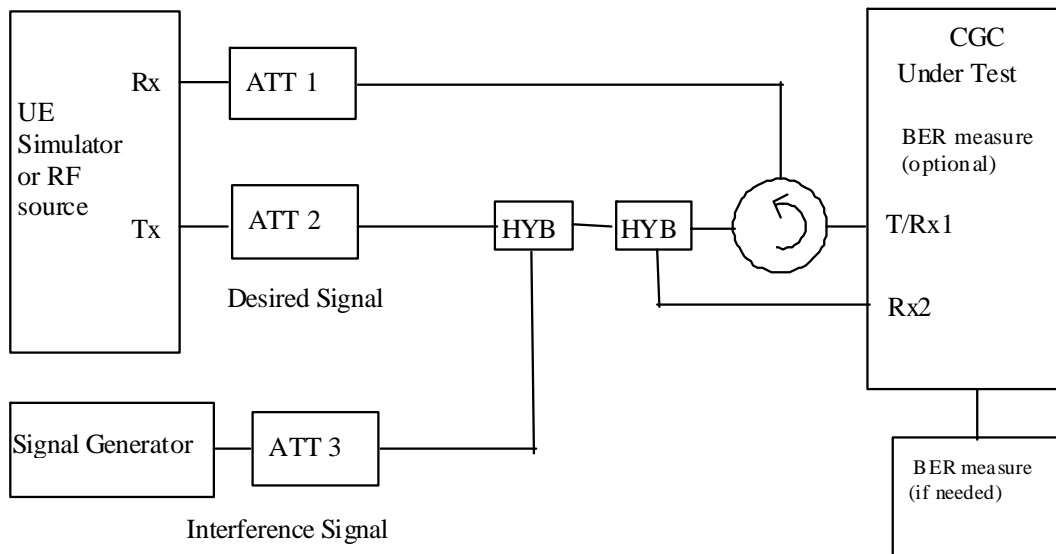

Figure D.5: Measuring system Set-up for Blocking characteristics

D.2.3 Intermodulation characteristics

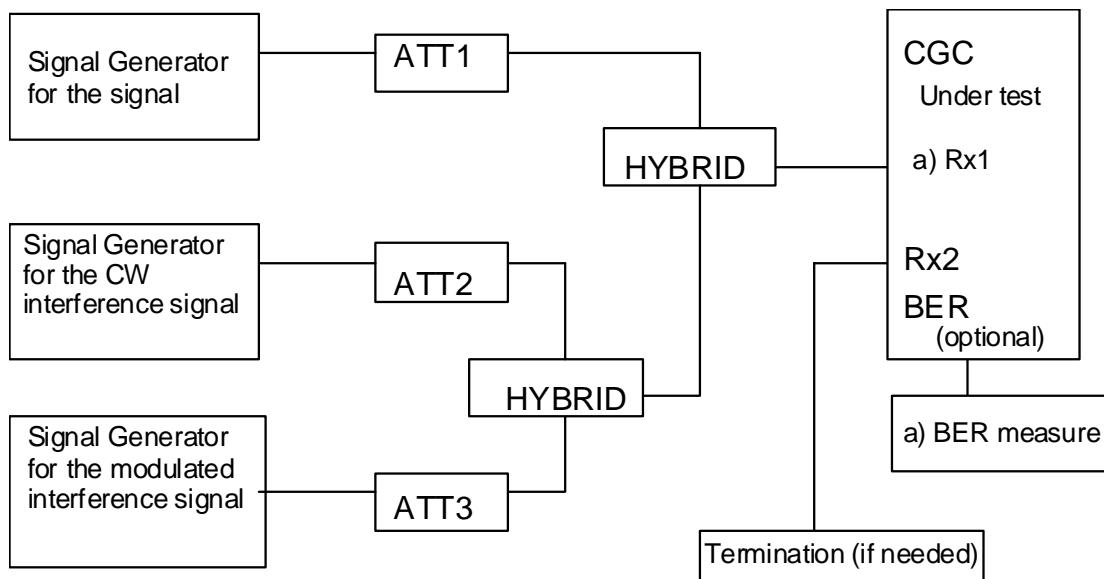

Figure D.6: Measuring system Set-up for intermodulation characteristics

D.2.4 Receiver spurious emission

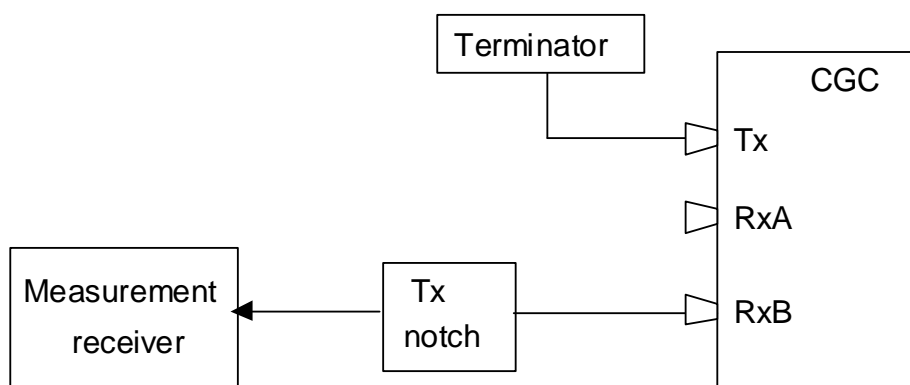

Figure D.7: Measuring system Set-up for Receiver spurious emission

Annex E (informative): The EN title in the official languages

The enlargement of the European Union (EU) resulted in a requirement from the EU for a larger number of languages for the translation of the titles of Harmonized Standards and mandated ENs that are to be listed in the Official Journal to support the implementation of this legislation.

For this reason the title translation concerning the present document can be consulted via the [e-approval](#) application.

Annex F (informative): Bibliography

- Council Directive 89/336/EEC of 3 May 1989 on the approximation of the laws of the Member States relating to electromagnetic compatibility (EMC Directive).
- Directive 2004/108/EC of the European Parliament and of the Council of 15 December 2004 on the approximation of the laws of the Member States relating to electromagnetic compatibility and repealing Directive 89/336/EEC.
- Council Directive 73/23/EEC of 19 February 1973 on the harmonization of the laws of Member States relating to electrical equipment designed for use within certain voltage limits (LV Directive).
- ITU-R Recommendation SM.1539: "Variation of the boundary between the out-of-band and spurious domains required for the application of Recommendations ITU-R SM.1541 and ITU-R SM.329".

History

Document history		
V1.1.0	November 2009	Public Enquiry PE 20100311: 2009-11-11 to 2010-03-11
V1.1.1	June 2010	Vote V 20100801: 2010-06-02 to 2010-08-02
V1.1.1	August 2010	Publication